

UNITED BLOWER INC., ESTABLISHED IN 1989, HAS OVER 10,000 BLOWER SYSTEMS INSTALLED TO DATE. WE SERVE THE WATER AND WASTEWATER MUNICIPAL MARKETS AS WELL AS PNEUMATIC AND INDUSTRIAL PLANT APPLICATIONS. OUR PRODUCT LINE INCLUDES A MULTITUDE OF STYLES RANGING FROM MULTISTAGE CENTRIFUGAL, REGENERATIVE, HIGH SPEED TURBO, AND POSITIVE DISPLACEMENT BLOWER PACKAGES. WE OFFER OUR FLAGSHIP PREMIUM PD QUIET PULSE PACKAGE AS WELL AS OUR ECONOMICAL ENVIROPAK, ECONOPAK, & ECONOTOP DESIGNS. UBI ALSO FURNISHES DROP-IN AND RETROFITTED BARE SHAFT BLOWER REPLACEMENTS IN ADDITION TO A VAST INVENTORY OF REPLACEMENT PARTS. LET UNITED BLOWER BECOME YOUR ONE STOP SHOP FOR ALL OF YOUR AERATION NEEDS.

ECONOTOP PD BLOWER PACKAGES



FEATURES

- PACKAGES MANUFACTURED IN BALL GROUND, GA SINCE 1989
- 230V/ 460V/ 575V UP TO 30 HORSEPOWER
- 2 LOBE & 3 LOBE PD BLOWERS WITH PULSE CONTROL CHANNELS
- ALTERNATIVE ULTRA EFFICIENT TWO LOBE BLOWERS
- MOTOR SLIDE BASE BELT TENSIONER
- 14-20 dB SOUND ATTENUATING ENCLOSURE
- 3-SIDED ACCESSIBLE SOUND ENCLOSURES
- INSTRUMENTATION AS REQUIRED.

United Blower, Inc.
1198 Airport Dr
Ball Ground, GA 30107
Office: (770) 479-3000
www.unitedblowerinc.com
sales@unitedblower.com



UBI ECONO-TOP SERIES BLOWER PACKAGE

Features:

1. UBI Blower
2. 230/460 V TEFC Motor w/ Motor Slide Base
3. Drive Guard
4. Inlet Filter Silencer
5. Discharge Silencer
6. ECONO-TOP Series Elevated Base
7. ECONO TOP 1" Thick Enclosure
8. Standard Accessories
 - A. 0-15 PSIG Pressure Gauge
 - B. 50-300°F Temperature Gauge
 - C. Filter Restriction Gauge
 - D. Rubber Flex Connector
 - E. Check Valve
 - F. Relief Valve
 - G. 1" THK Vibration Isolation Pads

All Panels Are Removable For Easy Access

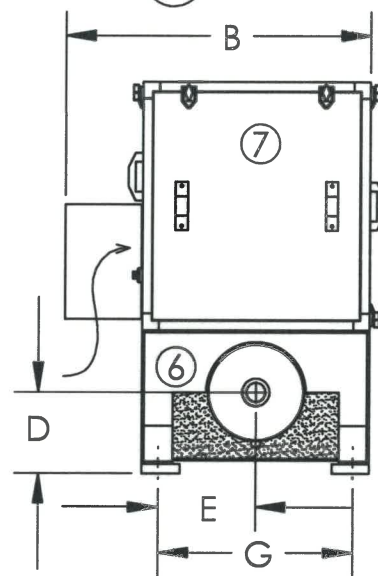
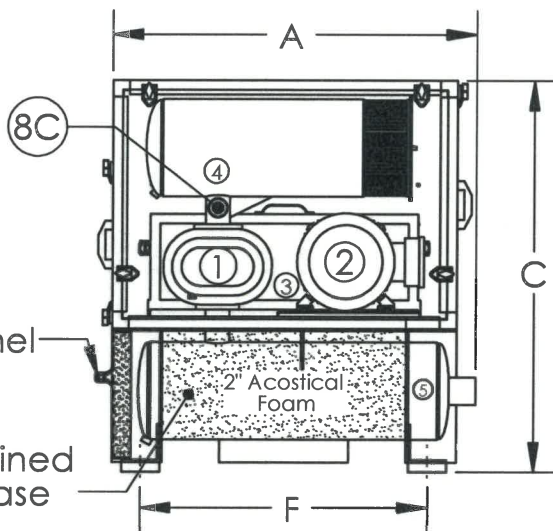
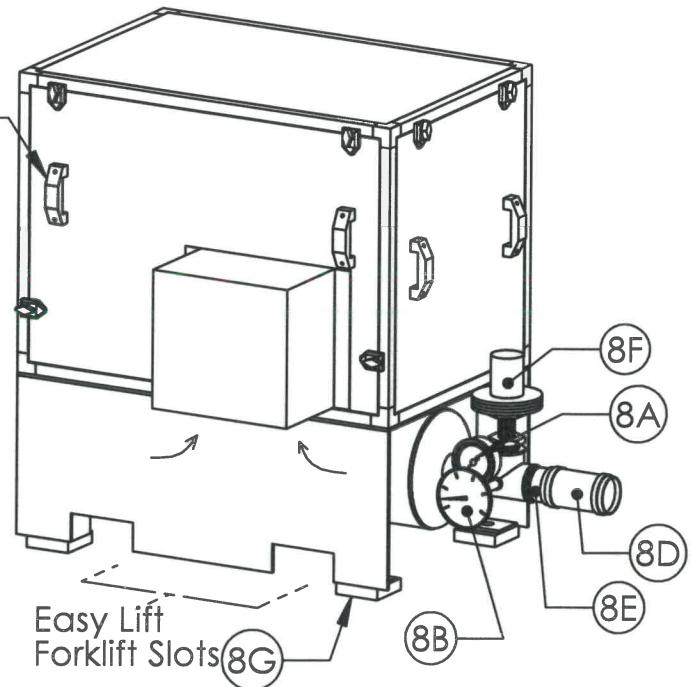

SIZE	A	B	C	D	E	F	G	OUTLET	AVAILABLE HP
------	---	---	---	---	---	---	---	--------	--------------

3	72	52	64	12	15.75	58.25	35.5	4-6"	25-30 HP
---	----	----	----	----	-------	-------	------	------	----------

DIMENSIONS IN INCHES

Note:

- United Blower offers to provide one coat of PPG 97-689 Multi Primer (Red) at 3.0 to 4.0 mil (DTF) per coat, followed by one finish coat of PPG AUE-300 Low VOC Polyurethane Paint (Safety Blue) at 2.0 to 3.5 mil (DTF) per coat
- United Blower offers to provide outer powder coating in a light reflecting light grey color over G-90 galvanized steel panels receiving a single electrostatic spray at 3.0 to 4.0 mil (DTF). Noise enclosure frame is powdercoated Safety Blue receiving a single electrostatic spray at 3.0 to 4.0 mil (DTF). Panels and frame are cured in an oven at 400°F.



UNITED
BLOWER
INC.
1198 AIRPORT DR
BALLGROUND, GA 30107
T: 770-479-3000

ECONO-TOP Series Blower Package



UIB UNITED
BLOWER
INC.

